



HUGE X

**INSTRUCTION MANUAL
FOR SPORTING OVER / UNDER**

**READ THE INSTRUCTIONS AND
WARNINGS IN THIS MANUAL CAREFULLY
BEFORE USING THIS FIREARM**

GUN SAFETY RULES

Observe these rules of safe gun handling.

1. Always keep the muzzle pointed in a safe direction. Watch the muzzle at all times: never point a gun, accidentally or intentionally, at any person or anything you do not intend to shoot. Identify the target before shooting; do not shoot at sounds.
2. Always treat a gun as if it is loaded—It may be!
3. Keep your finger off the trigger while operating the action and at all other times until you are ready to shoot.
4. Keep the safety “on” or in the “safe” position at all times until you are ready to fire.

Do not rely on your gun’s safety, the safety on any gun is a mechanical device and is not intended as a substitute for common sense or safe gun handling.

5. Learn how your gun functions and handles. If you do not thoroughly understand the proper use and care of your gun, seek the advice of someone who is knowledgeable.
6. Do not alter or modify any part of the firearm.
7. Store guns unloaded, separate from any ammunition and out of the reach of children.
8. Be sure the barrel is clear of any obstructions before loading. Make it a habit to check the barrel every time before loading.
9. Be sure you have and use the proper ammunition. A 20 gauge shell will enter a 12 gauge chamber far enough so that a 12 gauge shell can be loaded behind it. Also, a 3 inch shell may fit into a 2 3/4 inch chamber, but the crimp at the mouth of the shell will unfold into the forcing cone.
10. Wear protective shooting glasses and adequate ear protection when shooting.

11. Never climb or jump over anything, such as a tree, fence, or ditch, with a loaded gun. Open the barrel, remove the shells and hand the gun to someone else or place it on the ground on the other side of the obstacle before crossing it yourself. Do not lean a gun against a tree or other object; it could fall and possibly discharge.
12. Do not shoot at a hard surface or at water. Bullet and shot can ricochet or bounce off and travel in unpredictable directions with great velocity.
13. Never transport a loaded gun. DO not place a loaded gun into a vehicle. The gun should be unloaded and placed into a case when not in use.
14. Never drink alcoholic beverages before or during shooting.

INTRODUCTION HUGEX

For many years, HUGEX has been exporting and manufacturing quality shotguns. Combine the old world quality with modern technology, and you have HUGEX.

We at HUGEX thank you for the privilege of delivering a product to you that will provide you with years of pleasurable use. Happy shotgunning.

ABOUT YOUR OVER & UNDER SHOTGUN

Two firing mechanisms are available in these double barrel shotguns. Boxlocks house the firing mechanism behind a false breech and are enclosed in a metal frame.

To remove or unload shot shells, our shotguns have extractors and ejectors. The extractor model elevates the head of a live (or spent) shell from the chamber so it can be removed manually. Ejectors do what you would imagine; they eject the fired shell from the barrel. Our ejectors are automatic selective ejectors which mean they eject only fired shot shells. Triggers come in three types; double, single, and single selective. Double triggers have one barrel assigned to each triggers. The single trigger fires the barrels in a set order. The single selective trigger works like the single trigger, except it has a button that allows you to select which barrel fires first. HUGEX Over & Under shotguns come with single selective triggers. The selection is located on the safety. Push the safety (while in the safe position) to the left side to fire the top barrel first and to the right to fire the bottom barrel first.

SAFETY BUTTON

A. The safety switch (button) is located on the top tang of your firearm.
B. To engage the safety, slide the button rearward so the letter "S" is visible. The safety should always be in the "on" or "safe" position until the time you intend to fire.

C. When you are ready to fire the shotgun, slide the safety button forward to the "off safe" position so that the letter "S" is not visible. of the barrels until the action closes. Release the hinge pin and notch and the barrels will be locked in place.

WARNING: Do not rely solely on your gun's safety. Treat every gun as if it is loaded and ready to fire. The safety is a mechanical devise and is not intended to serve as a substitute for common sense or safe gun handling. Always keep the muzzle pointed in a safe direction.

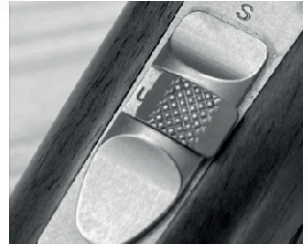

DANGER: The shotgun will fire when the trigger is pulled when the safety button is in the forward or "off" position and the "S" does not show. Always keep the muzzle pointed in a safe direction.

ASSEMBLY

Make sure there are no shells in the chamber.

1. Remove all dirt and excess oil from gun, especially from the breech area, also barrel interior and ends.

2. Remove the forearm by pushing the forehand iron catch upwards, this allows the nose of the forearm to release. With your other hand and at the same time you are pushing the iron catch release upwards, separate the forearm from the barrel (**Photo 1**).

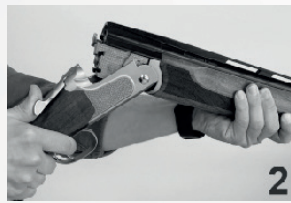

3. Lightly oil the already cleaned contact points. Attach barrels to action by grasping the grip of the stock with your right hand and placing the stock under your right arm. With your right thumb move the opening lever to the right. Now hold the barrels with the barrel's nose pointing down until the hinge the top of the receiver, with the barrels nose pointing down until the hinge notch engages with the hinge pins (Photo 2).

4. Keeping the hinge pins locked engaged with the hinge pin, lift the nose of the barrels until the action closes. Caution: If you attempt to close the gun and the barrels bind and don't seem to fit the hinge pin and notch are not engaged. DO NOT FORCE, try again. Release the hinge pin and notch and the barrels will be locked in place.

5. Replace the forearm on the gun by sliding the rear of the forearm into the barrel at the same angle by which you removed it. The round rear of the forearm should match the round front of the receiver. Lift the nose of the forearm until it engages with the barrels with an audible "click." If the forearm release latch protrudes after the "click," gently push it in place. (Photo 3)



LOADING AND OPERATING YOUR SHOTGUN

1. Slide the safety, located on the tang of the receiver, toward the butt of the gun into the "safe" position (Photo 4).

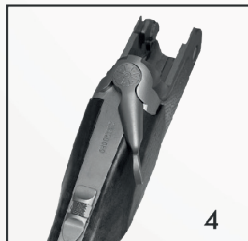

2. Break the action open.

3. Check the barrels for any obstruction, including dirt and excess oil. **CAUTION: Obstructions can increase barrel pressure sufficiently so that the barrel can explode when the gun is fired. This may result in serious injury or death to the shooter and others in the vicinity.**

4. Insert the shot shells into the chamber or chambers you plan to fire. **CAUTION: Make sure the shells are of the proper gauge and chamber length for your gun.**

HUGEX is not responsible for damage to a gun or shooter caused by malfunctioning ammunition, new, remanufactured, reloaded, or hand loaded.

5. Close the action.

6. The order in which the barrels are fired depends upon the selective trigger.

7. When contemplating firing your gun, be sure of your target, what is behind it, and the location of all persons with you or in your vicinity. Pick your target, release the safety by sliding it forward with your thumb and squeeze the trigger with your forefinger.

8. To unload, press the opening lever to the right and open the action. Fired shells will be ejected and unfired shells will be elevated above the chamber on models with automatic selective ejectors. Models with extractors will only elevate both fired and unfired shells above the chamber.

CAUTION: In case of a misfire, wait at least 30 seconds while keeping the gun pointed in a safe direction. Then, carefully open the action away from yourself and others. If the primer or the rim is indented, the shell should be discarded in a manner that would prevent accidental injury to you and others. If there is no indentation on the primer or rim, your gun has malfunctioned and should be serviced by a qualified gunsmith. If the gun is under warranty it must be serviced by an authorized gunsmith to not void warranty.

DISASSEMBLY

1. Make sure the gun is unloaded and no shells are in the chamber.

2. Close the action. Place the gun butt on your thigh and remove the forearm by pulling the forearm release latch or pressing the forearm release button. While pulling the nose of the forearm away from the barrels, slide the forearm forward until separated from the barrels.

3. Separate the barrels from the receiver by holding the stock of the gun in your right hand and the barrels in your left. Push the opening lever to the right with your thumb. Allow the nose of the barrels to drop and lift the barrels upward out of the receiver.

4. Close the top lever by pressing on the button located in the action (Photo 5)

5. The gun can now be cleaned. The forearm should be reattached to the barrels for storage.

6. If your gun is DLX model, please follow the below instructions to remove/install the trigger group:

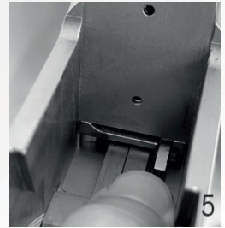

Removing the Trigger Group:

To remove trigger group, push down on the top button then push safety forward over the button. This will unlatch the trigger group from the receiver allowing the user to remove it.

NOTE: Do NOT dryfire the hammers while trigger group is removed from the receiver. By doing so could cause damage to the trigger group frame.

Installing the Trigger Group:

To install trigger group the user must place the front of the trigger group inside of the receiver then push the rear portion up until the trigger group clicks into place. To ensure trigger group is locked into place the user can use the palm of their hand to gently strike the trigger guard upwards.

CAUTION: No further disassembly is needed, unless it is done by persons qualified in shotgun repair. Improper functioning and damage to the gun may result otherwise.

MAINTENANCE AND CLEANING

CAUTION: Make sure the gun is UNLOADED.

1. Make sure the broad, polished finely fitted mating surface of the breech block and receiver is especially clean and lightly oiled with high quality gun oil. Do not use silicone or lanolin (Do not use WD-40).

2. Run an oil patch through the bore with a cleaning rod starting from the breech end. To prevent leading, use a cleaning solvent and brass brush to clean the bore periodically. Follow this cleaning with one or two clean oil patches.





IMPORTANT: If your gun is equipped with choke tubes, do not use a brass brush to clean the barrels without having a choke tube installed. Barrels that utilize choke tubes must also have the choke tubes removed to clean and oil the threads inside the barrel and the choke tubes themselves. This will protect the threads and prevent dirt build up that can cause tubes to become difficult to remove.

Never fire your gun without choke tubes snugly tightened in barrels. Do not over tighten choke tubes. Wipe all exposed metal surfaces with an oiled cloth before storing. Do not squirt or pour oil into the inside mechanism because it may hamper proper functioning. After extended periods of heavy use, your gun should be taken to a qualified gunsmith to have the action disassembled for professional cleaning and lubrication.

3. Care for your wood stock and forearm the same way you would a piece of furniture with the same finish.

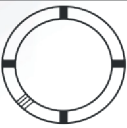
STORAGE

Clean thoroughly and oil your gun before storage. Store the gun in a case to prevent scratches and dents. Store your firearm in a dry place to prevent corrosion. Store the gun away from children and in a place where it cannot be obtained by those unauthorized to use it. Always store gun unloaded and separately from any ammunition.

	SKEET	IC	M	IM	F
CHOKE TUBE					
BBLs	CL	HHHH	HHH	HH	H

The choke controls how open or tight the pattern of the shot will be. The chart below lists the chokes available (from open to tight), and the corresponding marks that indicate the specific choke.

Never fire your gun or run cleaning tools through a barrel that uses a choke tube without having a choke installed. The threads of the choke tube and the internal threads of the barrel should be cleaned after each use and before installation of the tube.

To install a tube, insert the tube into the top of the barrel and tighten with your fingers. Once the tube is finger tightened, tighten the rest of the way with the appropriate choke tube wrench until the tube is snug. DO NOT over tighten or forcefully tighten with the wrench.

IMPORTANT USAGE OF STEEL SHOT

The choke (constriction) in all modern shotguns has been established based on the pattern performance of shot shells loaded with lead shot. When using steel shot shells, you will notice a different performance in pattern density versus the established lead shot pattern, because steel shot is harder and lighter than lead shot.

You should be aware of the following differences and cautions: **Never shoot steel shot loads in a full choked barrel or an improved modified choked barrel. To do so may cause the barrel to swell or rupture.** In general, steel shot fired with a modified choke will produce the equivalent of a lead full choke pattern. This will be true of all steel shot sized up to and including no. 2. The established improved cylinder chokes will produce the equivalent of a (lead) modified pattern. All steel shot sized larger than no. 2, and including special sized such as F, T, etc., should be used only with improved cylinder chokes. These steel shot sizes, when used in an improved cylinder choke, will produce equivalent to (lead) full choke patterns. The established cylinder choke or bore will produce the equivalent of a modified (lead) pattern. Additional information concerning the use of steel shot is available from the ammunition companies.

HAZARDOUS MATERIAL WARNING

Discharging firearms in poorly ventilated areas, cleaning firearms, or handling ammunition, may result in exposure to lead and other substances known to cause birth defects, reproductive harm, and other serious injury. Have adequate ventilation at all times. Wash hands thoroughly after exposure.

COMB ADJUSTMENTS:

Comb adjustments can be made for both cast on and cast off as well as for drop at comb. CAST ON AND CAST OFF ADJUSTMENTS ARE A MATTER OF TRIAL AND ERROR. Comb adjustments will require the SILVER Allen Wrench that was provided in the choke tube box.

1.To adjust comb for cast use the SILVER Allen Wrench to remove the comb from the stock. Insert the Allen Wrench in the each of the holes and loosen the set screws. Approximately three full turns will loosen the set screws enough to remove the comb. (PHOTO 6)

2.Once the comb is removed, continue to use the SILVER Allen Wrench to adjust the posts position at the top of each post to obtain the desired cast. Adjust both posts to the RIGHT to acquire Cast Off which is desired by Right-handed shooters. Adjust both posts to the LEFT to acquire Cast On which is desired by Left-handed shooters. A combination of moves might need to be made to obtain the desired position. (PHOTO 7)

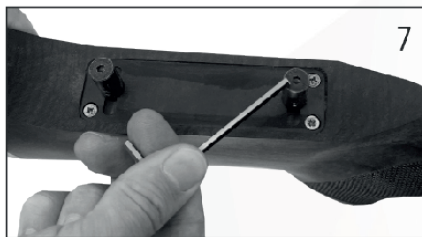
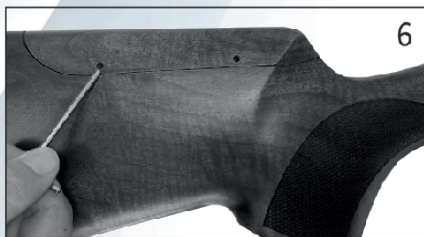

COMB DROP AT COMB ADJUSTMENTS ARE A MATTER OF TRIAL AND ERROR.

1.To adjust for drop at comb continue to use the SILVER Allen Wrench to raise and lower the comb from the stock. To decrease the drop at comb, comb must be raised to the desired height. Spacers have been provided to assist with adjustments which can be found in the choke tube box.

The spacers can be used to obtain and maintain the desired drop at comb. Place a spacer around each post gradually to obtain the desired drop at comb.

2.To increase drop at comb, comb must be lowered to desired height. This position may or may not require any spacers. Use the spacers provided to obtain the desired position.

3.When the desired cast and drop at comb have been obtained tighten the two set screws in the comb. Do not over tighten.

BARREL RIB ADJUSTMENTS:

1. To adjust rib for desired positioning use the BLACK Allen Wrench to loosen both set screws at the rib pivot point, located at the middle of the rib. Only loosen the set screws enough to allow movement, as completely removing the screws could result in the loss of parts. Approximately two full turns will loosen the set screws enough for movement. (PHOTO 8)

FAILURE TO LOOSEN BOTH SET SCREWS PRIOR TO ANY FURTHER ADJUSTMENTS OF THE RIB MAY RESULT IN LIMITED ABILITY TO ADJUST THE RIB VERTICALLY AND/OR ACCIDENTAL BENDING OF THE RIB.

2. To adjust the Point of Impact the front adjustment can be raised or lowered. This will allow the POI to be set at the desired position. To adjust the rib use the BLACK Allen Wrench and slide it through the hole of the detent spring (PHOTO 9). Once this has been done, pull back on the Allen Wrench relieving the tab from its original slot. This will allow the tab to be moved up or down to the proper position to obtain the desired height. (PHOTO 10)

3. To adjust the sight picture the rear adjustment can be raised or lowered. This will allow the sight picture to be set at the desired position. (Follow the same procedure as the adjustment for POI).

4. When the desired height and positioning of the rib has been obtained tighten the two set screws at the rib pivot point located at the middle of the rib. Do not over tighten.

DO NOT FIRE THE SHOTGUN WITH LOOSE OR MISSING RIB SET SCREWS AS THIS MAY CAUSE SIGNIFICANT DAMAGE TO BOTH THE RIB AND SHOTGUN.

5. If further adjustments are required for the rib, follow the above procedures each time the rib is adjusted.

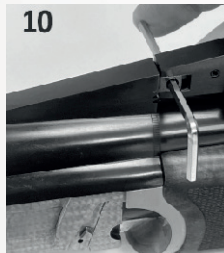
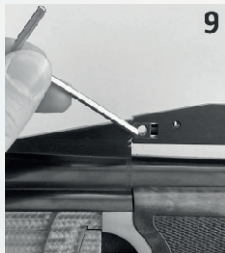
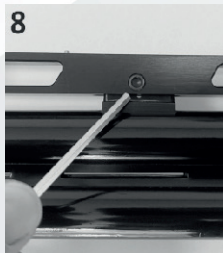

IF YOUR SHOTGUN HAS AN ADJUSTABLE RECOIL PAD SYSTEM

How to adjust your Adjustable Recoil Pad:

To remove the recoil pad from the stock, insert the Allen Wrench provided with the firearm into the left side of the lower plate of the recoil pad. Loosen the screws roughly two turns. **Do not remove screws completely.** This will allow you to slide the recoil pad all of the way out of the stock for greater ease of adjustments.

-To lower the recoil pad, use the same Allen Wrench and loosen the middle screw. Once this is done you can lower and raise the recoil pad to the height that is desired. After adjustment tighten the screw back. **Do not overtighten.**

-To adjust the Drop at Heel/Drop at Toe on the recoil pad, use the same Allen Wrench to loosen the top and bottom screws on the bottom of the recoil plate. Once these are loosened you will be able to adjust the pitch of the recoil pad to the desired position. By loosening the bottom screw and tightening the top screw you will be able to adjust for the drop at toe. By tightening the bottom screw and loosening the top screw you will be able to adjust for the drop at heel.

-To change the cant of the recoil pad, use the same Allen Wrench to loosen the screws on the bottom of each post. By loosening these screw you can slide the post left or right. By sliding the top post to the left and the bottom post to the right the cant of the top of the recoil pad will be to the right, and the bottom of the recoil pad will be to the left, offsetting each other. By sliding the top post to the right and the bottom post to the left the cant of the top of the recoil pad will be to the left and the bottom of the recoil pad will be to the right, offsetting each other. By sliding both post to the left will shift the recoil pad to the right. By sliding both posts to the right will shift the recoil pad to the left. Once the desired position is found tighten both screws on the bottom of each post. **Do not overtighten.**

-To adjust the length of Pull, use the spacers that were included with the firearm. Each spacer has been engraved for easy indication as to how wide they are. Included are two quarter-inch spacers, two half-inch spacers, and two 1-inch spacers. The spacers can be installed by sliding them over the recoil pad posts. This must be done after the recoil pad has been removed from the stock.

-To install the recoil pad to the stock, slide each post into the slots on the top of the lower plate. Once install use the same Allen Wrench to tighten both screws on the left side of the lower plate. Do not overtighten.

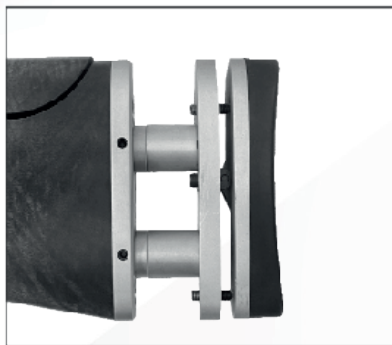
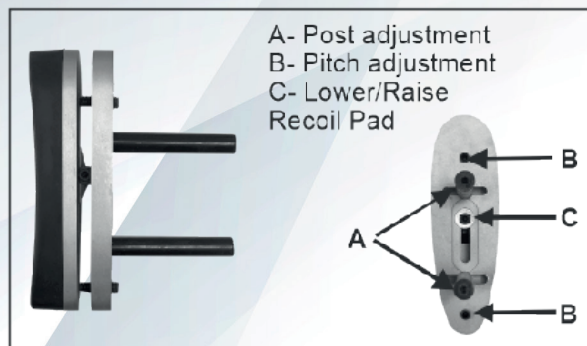

SPORTING MODEL



SPORTING MODEL PART LIST

1	Receiver	29	Trigger	57	Barrel
2	Left & Right Hinge Pin	30	Trigger Pin	58	Top Band
3	Receiver Bottom Plate	31	Trigger Spring	59	Ejector Right
4	Receiver Bottom Plate Pin	32	Trigger Detent Pin	60	Ejector Left
5	Top Lever Lock	33	Transfer Block	61	Ejector Spring Right and Left
6	Top Lever Lock Spring	34	Transfer Block Pin	62	Ejector Spring Pin Right and Left
7	Top Lever Lock Pin	35	Safety Bottom	63	Ejector Locking Right
8	Blocker Plate	36	Safety Top	64	Ejector Locking Left
9	Top Lever	37	Safety Selector Plate	65	Ejector Locking Pin Spring
10	Top Lever Spring	38	Safety Spring	66	Ejector Locking Pin
11	Top Lever Detent Pin	39	Safety Pin	67	Forearm Lug
12	Top Firing Pin	40	Trigger Guard	68	Barrel Swivel Stud
13	Bottom Firing Pin	41	Trigger Guard Pin	69	Front Sight
14	Bottom Firing Pin Spring	42	Stock	70	Rib Vibration Damper (Front)
15	Top and Bottom Firing Pin Retaining Pin Right and Left	43	Stock Bolt	71	Rib Vibration Damper (Middle)
16	Cocking Rod Right	44	Stock Bolt Washer	72	Rib Vibration Damper (Rear)
17	Cocking Rod Left	45	Recoil Pad	73	Rib Adjusting Pin (Front)
18	Hammer Right	46	Recoil Pad Screw	74	Rib Adjusting Pin (Rear)
19	Hammer Left	47	Stock Swivel Stud	75	Rib Adjusting Pin Spring (Rear)
20	Hammer Pin	48	Adjustable Cheek Piece	76	Rib Adjusting Pin Spring Stud
21	Hammer Spring Guide Rod Right and Left	49	Stock Adjustment Plate	77	Rib Poise Stud
22	Hammer Spring Right and Left	50	Stock Adjustment Set Screw	78	Wooden Forearm
23	Hammer Spring Pin Washer	51	Stock Adjustment Bottom Plate	79	Forearm Iron
24	Hammer Spring Pin Washer Detent Pin	52	Stock Adjustment Stud	80	Forearm Latch Frame
25	Right Sear	53	Stock Adjustment Stud Screw	81	Forearm Latch
26	Left Sear	54	Stock Adjustment Bottom Plate Screw	82	Forearm Latch Spring
27	Sear Spring	55	Stock Adjustment Screw Washer	83	Forearm Latch Pin
28	Sear Pin	56	Stock Adjustment Nut	84	Forearm Latch Screw Pin
				85	Forearm Latch Screw
				86	Forearm Bolt
				87	Mobile Choke

HUNTING MODEL PART LIST

1	Receiver	25	Right Sear	48	Barrel
2	Left & Right Hinge Pin	26	Left Sear	49	Top Band
3	ReceiverBottom Plate	27	Sear Spring	50	Ejector Right
4	ReceiverBottom Plate Pin	28	Sear Pin	51	Ejector Left
5	Top Lever Lock	29	Trigger	52	Ejector Spring Right and Left
6	Top Lever Lock Spring	30	TriggerPin	53	Ejector Spring Pin Right and Left
7	Top Lever Lock Pin	31	TriggerSpring	54	Ejector Locking Right
8	BlockerPlate	32	TriggerDetent Pin	55	Ejector Locking Left
9	Top Lever	33	Transfer Block	56	Ejector Locking Pin Spring
10	Top LeverSpring	34	Transfer Block Pin	57	EjectorLocking Pin
11	Top LeverDetent Pin	35	Safety Bottom	58	Forearm Lug
12	Top Firing Pin	36	Safety Top	59	Barrel Swivel Stud
13	Bottom Firing Pin	37	Safety Selector Plate	60	Front Sight
14	Bottom Firing Pin Spring	38	Safety Spring	61	Choke
15	Top and Bottom Firing Pin Retaining Pin Right and Left	39	Safety Pin	62	Wooden Forearm
16	Cocking Rod Right	40	Trigger Guard	63	Forearm Iron
17	Cocking Rod Left	41	Trigger Guard Pin	64	Forearm Latch Frame
18	HammerRight	42	Stock	65	Forearm Latch
19	HammerLeft	43	Stock Bolt	66	Forearm Latch Spring
20	HammerPin	44	Stock Bolt Washer	67	Forearm Latch Pin
21	Hammer Spring Guide Right And Left	45	Recoil Pad	68	Forearm Latch Screw Pin
22	Hammer Spring Right And Left	46	Recoil Pad Screw	69	Forearm Latch Screw
23	Hammer Spring Pin Washer	47	StockSwivel Stud	70	Forearm Bolt
24	Hammer Spring Pin Washer Detent Pin				

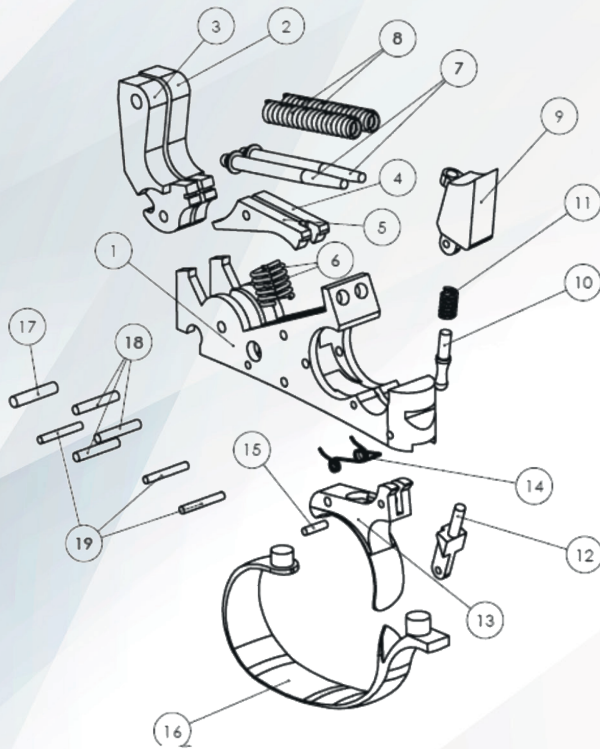

PART NO #	PART NAME
1	TRIGGER GROUP FRAME
2	RIGHT HAMMER
3	LEFT HAMMER
4	RIGHT SEAR
5	LEFT SEAR
6	SEAR SPRING
7	HAMMER SPRING PIN
8	HAMMER SPRING
9	HEAVY DUTY/IMPACT LATCH
10	HEAVY DUTY/IMPACT LATCH PIN
11	HEAVY DUTY/IMPACT LATCH SPRING
12	TRIGGER DROP LATCH
13	TRIGGER
14	TRIGGER SPRING
15	2*7,5 TRIGGER DROP LATCH PIN
16	TRIGGER GUARD
17	3*14,60 HAMMER PIN
18	2,5*14,60 TRIGGER AND SEAR PIN
19	2*14,60 TRIGGER GUARD IMPACT PIN

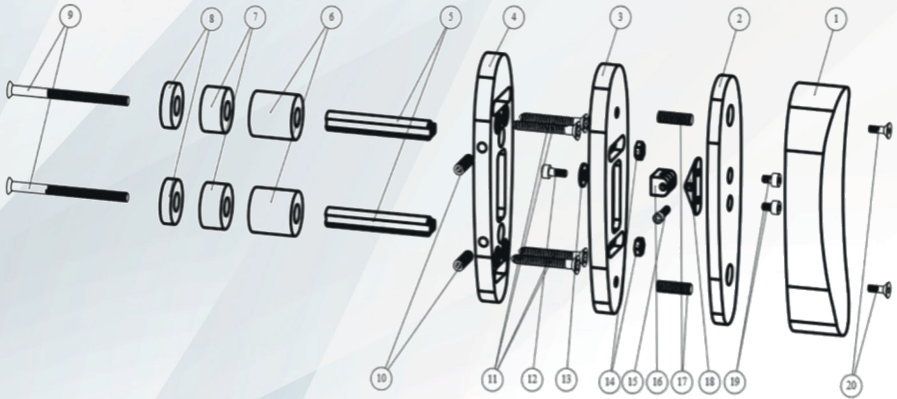

PART NO	PART NAME
1	RECOIL PAD
2	ALUMINUM RECOIL REDUCER REAR PLATE
3	ALUMINUM RECOIL REDUCER MIDDLE PLATE
4	ALUMINUM RECOIL REDUCER FRONT PLATE
5	RECOIL PAD POST
6	1" SPACER
7	1/2" SPACER
8	1/4" SPACER
9	RECOIL SYSTEM ADJUSTMENT SCREW
10	RECOIL PAD POST ADJUSTMENT SCREW
11	ALUMINUM FRONT PLATE ADJUSTMENT SCREW
12	ALUMINUM MIDDLE PLATE HINGE SCREW
13	ALUMINUM MIDDLE PLATE HINGE WASHER
14	RECOIL PAD ADJUSTMENT NUT
15	MIDDLE & REAR HINGE ADJUSTMENT SCREW
16	ALUMINUM MIDDLE PLATE HINGE
17	STOCK PITCH RETAINING SCREW
18	ALUMINUM REAR PLATE HINGE
19	ALUMINUM REAR PLATE HINGE SCREW
20	RECOIL PAD SCREWS

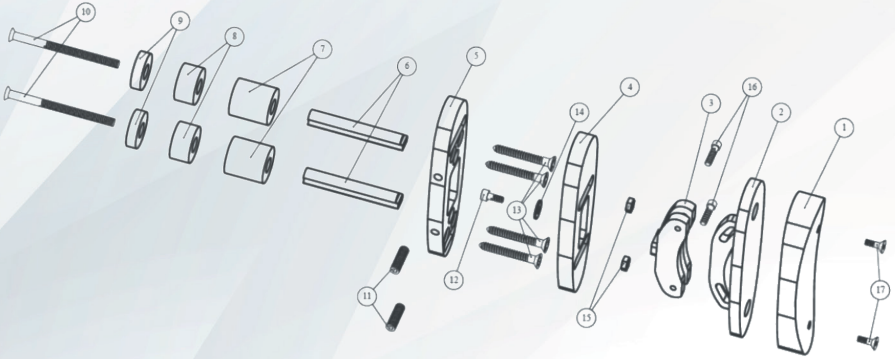

PART NO	PART NAME	QTY
1	RECOIL PAD	1
2	ALUMINUM RECOIL REDUCER REAR PLATE	1
3	ANGLE ADJUSTMENT JUNCTURE	1
4	ALUMINUM RECOIL REDUCER MIDDLE PLATE	1
5	ALUMINUM RECOIL REDUCER FRONT PLATE	1
6	RECOIL PAD POST	2
7	1" SPACER	2
8	1/2" SPACER	2
9	1/4" SPACER	2
10	RECOIL SYSTEM ADJUSTMENT SCREW	2
11	RECOIL PAD POST ADJUSTMENT SCREW	2
12	ALUMINUM MIDDLE PLATE ADJUSTMENT SCREW	1
13	ALUMINUM FRONT PLATE ADJUSTMENT SCREW	4
14	ALUMINUM MIDDLE PLATE ADJUSTMENT WASHER	1
15	RECOIL PAD ADJUSTMENT NUT	2
16	ANGLE ADJUSTMENT JUNCTURE HINGE SCREW	2
17	RECOIL PAD SCREWS	2

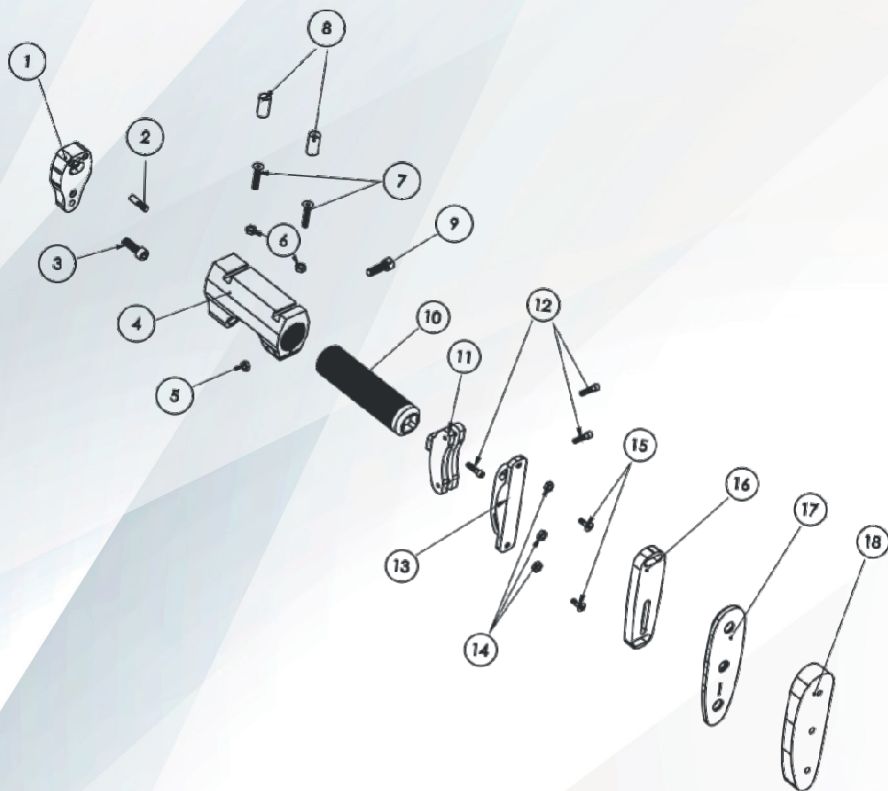

PART NO	PART NAME
1	STOCK CONNECTOR (PLATE)
2	CENTERING PIN
3	ADJUSTABLE STOCK BODY FIXING SCREW
4	ADJUSTABLE STOCK BODY
5	MOVEMENT FIXING NUT
6	MOVEMENT FIXING NUT
7	MOVEMENT FIXING SCREW
8	STOCK ADJUSTMENT STUD
9	MOVEMENT FIXING SCREW
10	PIPE
11	ANGLE ADJUSTMENT JUNCTURE
12	ANGLE ADJUSTMENT JUNCTURE FIXING SCREW
13	ALUMINIUM REDUCER FRONT PLATE
14	MOVEMENT FIXING NUT
15	MOVEMENT FIXING SCREW
16	ALUMINIUM REDUCER MIDDLE PLATE
17	ALUMINIUM REDUCER REAR PLATE
18	RF COIL PAD

SERVICE AGREEMENT AND LIMITED WARRANTY

HUGEX agrees to service its products free of charge for defects in materials and workmanship in accordance with the service agreement listed below.

The obligation of HUGEX under this agreement is limited to the repair or replacement of unserviceable parts and does not cover any incidental or consequential damages.

Other than the express warranty contained herein, HUGEX makes no warranties, expressed or implied.

HUGEX will repair or replace any unserviceable part(s) for (1) year from date of purchase and further will supply free parts (Wood not included) for an additional two (2) years in accordance with the above warranty statement provided your firearm had not been altered, abused, willfully damaged, or damaged by overpressure ammunition.

This agreement is not transferable; its benefits apply only to the original purchaser.

SHIPPING

When returning your firearm for service, please take care in packing.

Disassemble your gun wrap in a safe manner and place it in its original box.

(THIS BOX WILL PROTECT THE GUN BUT IS NOT DESIGNED FOR SHIPPING).

Wrap box in a cardboard box approved for interstate shipping.

HUGEX is not responsible for damage incurred during shipping.

NOTES

A series of horizontal dashed lines for writing notes.

HUGE 

Tepearası Mahallesi 83617. Sokak No:3 Derebucak/KONYA
info@hugexarms.com
+90 332 516 16 73